



topcoilsite.com

SUPER LIFT 25 TON ROD ELEVATOR Operators Manual



- 553-575-250
Plate Style 5/8 to 1-1/8 inch Sucker Rod
- 553-820-506
Solid Style 5/8-3/4 inch Sucker Rod
- 553-820-607
Solid Style 3/4-7/8 inch Sucker Rod
- 553-820-800
Solid Style 1 inch Sucker Rod
- 553-820-700
Solid Style 1-1/8 inch Sucker Rod
- 553-820-900
Solid Style 1-1/4 inch Sucker Rod
- 553-821-100
Solid Style 1-1/8 inch Polish Rod
- 553-821-300
Solid Style 1-1/4 inch Polish Rod
- 553-821-400
Solid Style 1-1/4 inch Fibreglass Rod
- 553-821-700
Solid Style 1-1/2 inch Polish Rod

Content	Page
Trico Customers.....	2
Assembly Drawing.....	3
Critical Area Drawing.....	4
Operation.....	5
Maintenance.....	6

Document: M2
Revision: C
Printed: April 2026
Author: Ryan Goudie

Thank-you for choosing Trico. We at Topco Oilsite Products design and build Trico equipment with you, the customer in mind.

To help ensure trouble-free operation of your equipment, read this manual carefully and follow its recommendations.

An authorized Topco facility knows your equipment best. When maintenance or service is necessary, that's the place to go.



General Cautions and Warnings

Maximum working load indicates the greatest force or load a product can carry under usual environmental conditions. Shock loading and extraordinary conditions will reduce the maximum working load rating. The maximum working load rating may also be affected by wear, misuse, overloading, corrosion, deformation, intentional alteration, and other use conditions.

Regular inspection shall be conducted to determine whether use can be continued at the maximum working load rating, a reduced maximum working load rating, or whether the product shall be withdrawn from service.

Important Notes About This Manual

All specifications and descriptions are accurate at the time of printing. Because continuous improvement is a goal at Topco, we reserve the right to make changes in specifications at any time without notice and without obligation.

Please be aware that this manual applies to all models, equipment, and options. As a result, you may find some explanations not applicable to your equipment.





Quality

If you have any questions, concerns, or feedback regarding the quality of our products and services please contact us.

Safety

Ensure equipment is operated in accordance with all government, regulatory and employer requirements.

Markings

-  This symbol in the manual means "Do not let this happen."
-  This symbol means a minimum operating temperature of -4°F (-20°C).
-  This symbol means a minimum operating temperature of -50°F (-46°C).
-  This symbol means failure to comply may result in damage or injury.

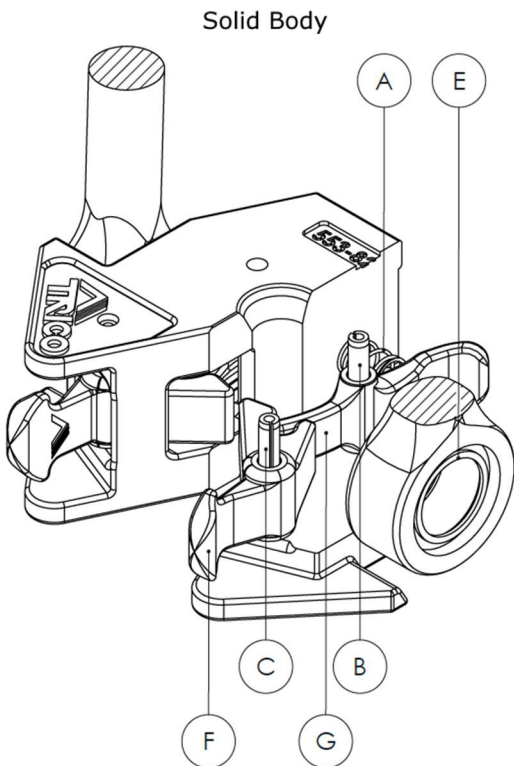
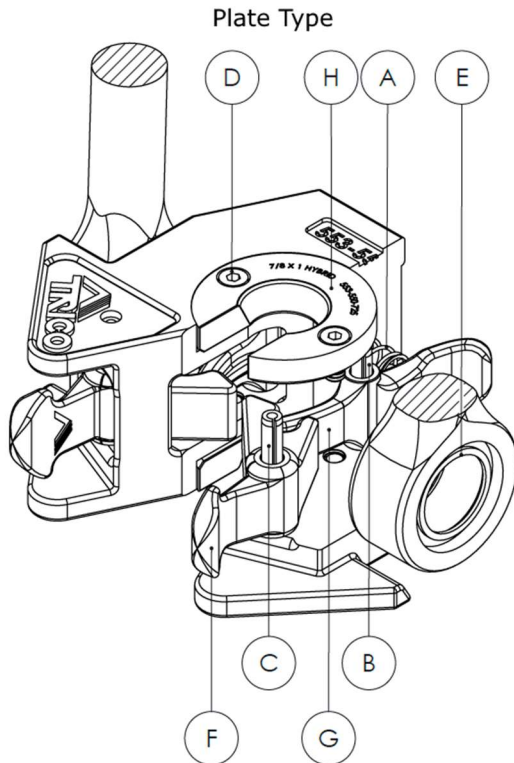

A. 2x Spring

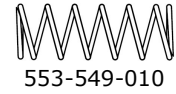

B. 2x Plate Drive Pin

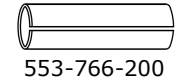

C. 4x Solid Drive Pin
(2x Plate Type)

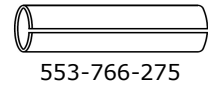

D. 4x Plate Screw

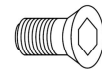

E. 2x Retaining Ring



F. 2x Front Latch

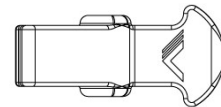

2x Front Latch
(Polish & Fibreglass Rod)

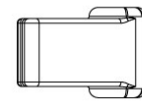

2x Front Latch
(1-1/2 Polish Rod)

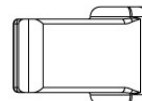

G. 2x Rear Lever



H. 2x Plate



Wear Limits			Critical Area
Trunnion	Trunnion Hole	Hook Seat	
Minimum 1.32 in (34 mm)	Maximum 1.46 in (37 mm)	Minimum 1.43 in (36 mm)	

Body

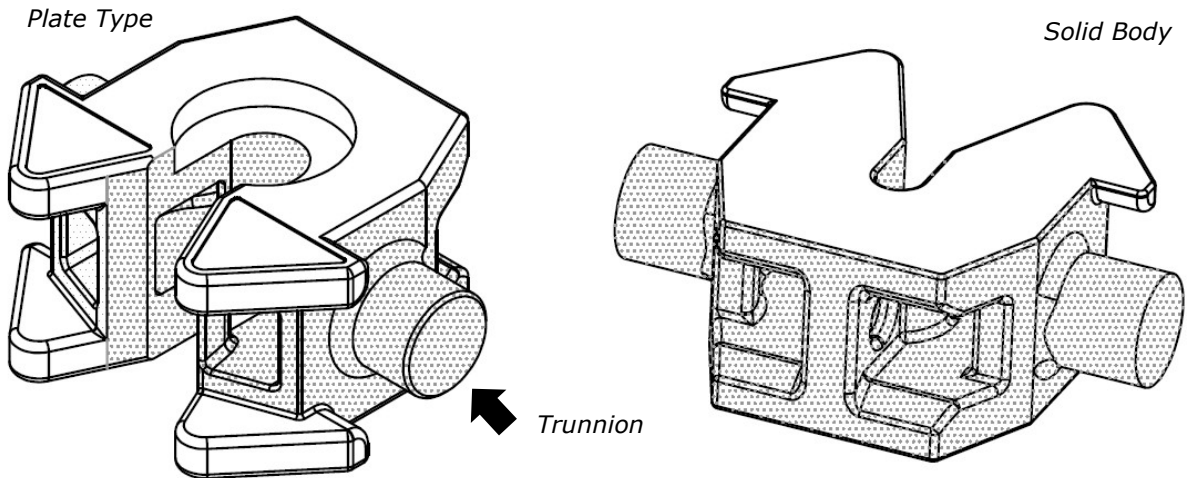

Bail

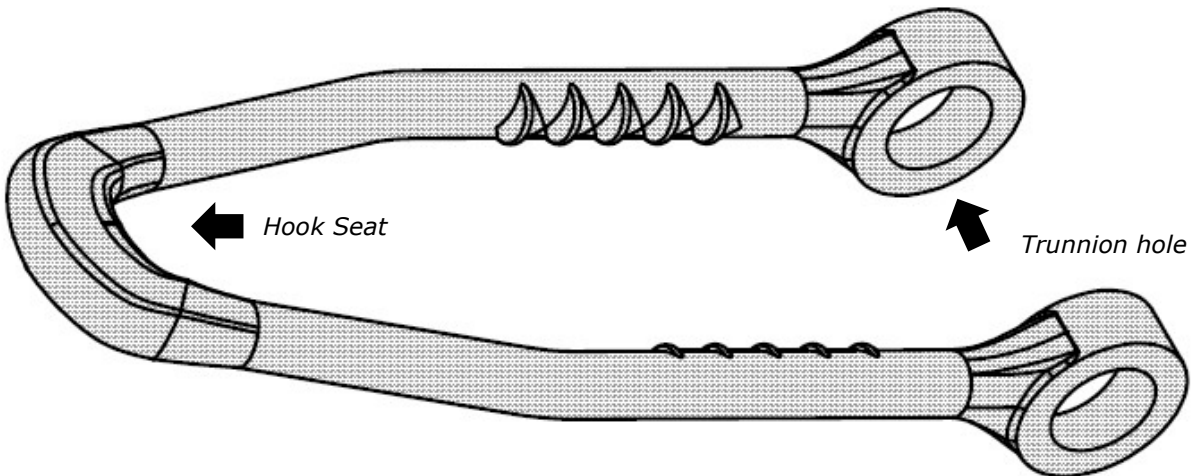

⚠ WARNING: Failure to follow these directions could result in damage or injury.

- ▶ Trico Rod Elevators are designed to elevate fibreglass, polished, pony and sucker rods. Never use them for any other purpose.
- ▶ Only lift rods in a vertical direction using the hook seat.
- ▶ Never use a plate type elevator without a plate and plate screws.
- ▶ Never use an elevator with an incorrect sized rod upset or rod size.
- ▶ Never exceed the maximum working load of the Elevator.
- ▶ Never operate below the minimum operating temperature.

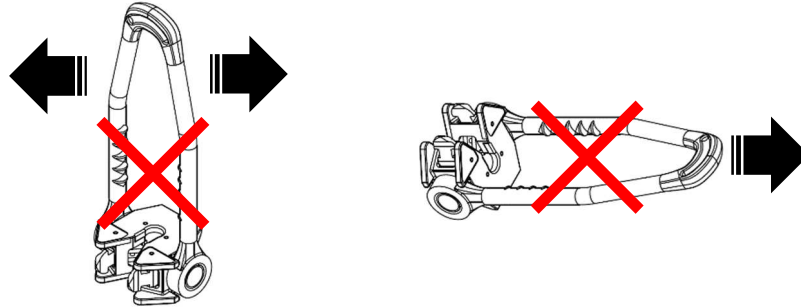

Super Lift New Equipment Specifications

- ▶ Maximum Working Load: 25 short tons (50,000 lbs).
- ▶ Minimum Operating Temperature: -50°F (-46°C).

Before Each Use

- ▶ Ensure the bail freely rotates in both directions, and is tightly secured to the body.
- ▶ Inspect the retaining rings, front latches and plates for damage.

Inserting and Removing Elevators

Engage either the front latch or rear lever **(A)** to insert and remove a rod **(B)**.

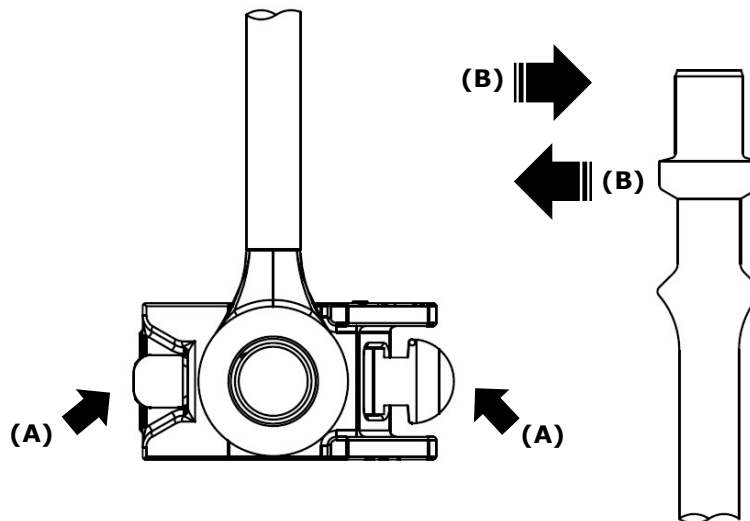



WARNING: Failure to follow these directions could result in damage or injury.

- ▶ Never weld, grind, or modify in any way.
- ▶ Only use Trico Original Equipment Manufacturer (“OEM”) replacement parts.



Recommended Maintenance Practice

API specification 8B is the recommended practice for the maintenance of Trico Rod Elevators. At a minimum, it is recommended that all category III and IV maintenance be conducted at an authorized Trico inspection facility.

Recommended Maintenance Schedule

This schedule is a guide only. The equipment owner/operator should consider the following factors when building a maintenance schedule; environment, load cycles and operating time.

Category	Type	Rate	Method	Corrective Action
I	Visual	-	<ul style="list-style-type: none"> • Observation during operation 	Contact Topco to locate an authorized Trico inspection facility.
II	Visual	1 day (Daily)	<ul style="list-style-type: none"> • Cracks • Loose connections • Yielding • Wear • Corrosion 	
III	Physical	6 months (Bi-annually)	<ul style="list-style-type: none"> • NDT of critical areas • Wear limits 	
IV	Disassembly	1 year (Annually)	<ul style="list-style-type: none"> • Inspection at an authorized Trico facility 	

Contact Information



OILSITE
TOPCO PRODUCTS USA

Permian Basin: 432 296 7040
ContactUs@TopcoOilsite.com
TopcoOilsite.com

